

Data sheet - HFHDS-M5-35

Self-clinching dog-point studs

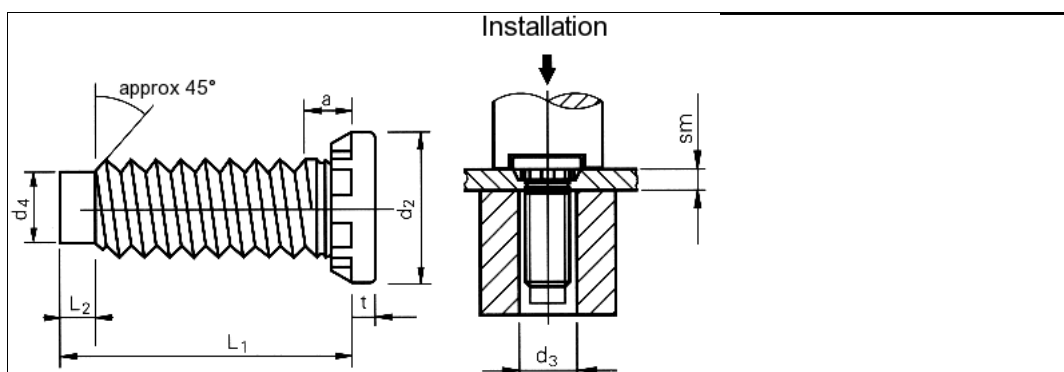

3D-Data available	
Application	Self-clinching studs with dog-point for automatic installation.
Order description	HFHDS-M5-35
Thread d1	M5
Hole-Ø in the sheet +0.13 0	5 mm
Min. edge distance up to the hole centre	10.7 mm
d4 ±0.13	3.66 mm
d3	5.1 mm
L2 ±0.25	1.78 mm
d2 ±0.25	7.8 mm
Max. a	2.7 mm
Max. t	1.14 mm
Min. sm	1.3 mm
L1 ±0.4	35 mm
Material	Passivated grade 18/8 stainless steel (AISI 300).
Use	For sheet hardnesses up to HRB 70.
Tools	
Insertion machines	

uniform resource locator: