

Data sheet - HFHDS-M6-40

Self-clinching dog-point studs

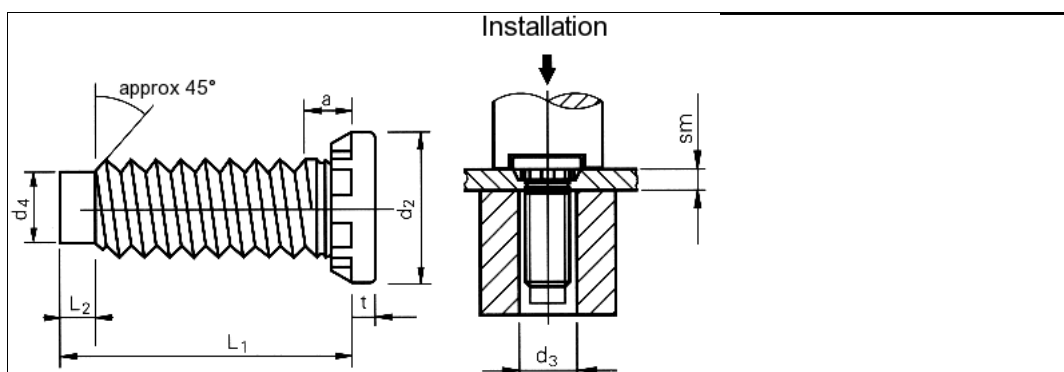

3D-Data available	
Application	Self-clinching studs with dog-point for automatic installation.
Order description	HFHDS-M6-40
Thread d1	M6
Hole-Ø in the sheet +0.13 0	6 mm
Min. edge distance up to the hole centre	11.5 mm
d4 ±0.13	4.37 mm
d3	6.1 mm
L2 ±0.25	2.03 mm
d2 ±0.25	9.4 mm
Max. a	2.8 mm
Max. t	1.27 mm
Min. sm	1.5 mm
L1 ±0.4	40 mm
Material	Passivated grade 18/8 stainless steel (AISI 300).
Use	For sheet hardnesses up to HRB 70.
Tools	
Insertion machines	

uniform resource locator: