

Data sheet - PLC-M4

Self-locking nuts

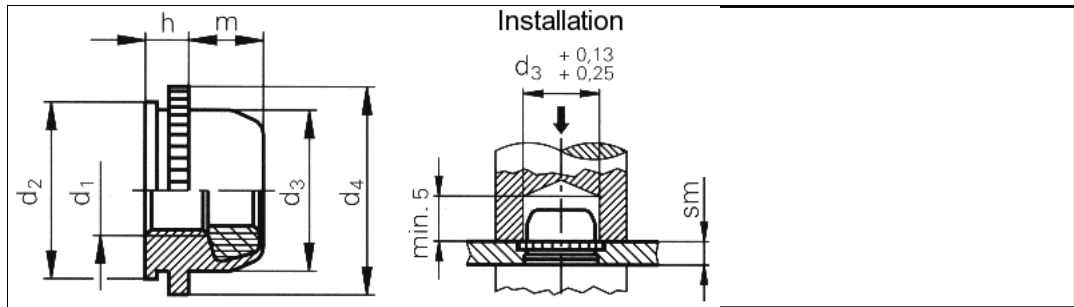

3D-Data available	
Application	Self-locking effect due to a nylon ring. Temperature resistant up to + 120 °C.
Order description	PLC-M4
Thread d1	M4
Hole-Ø in the sheet +0.08 0	7.5 mm
Max. d2	7.48 mm
Max. d3	7.01 mm
Max. d4	8.54 mm
Max. m	4.20 mm
Max. h	1.52 mm
Min. sm	1.5 - 1.8 mm
Min. edge distance up to the hole centre	5.59 mm
Material	Passivated grade 18/8 stainless steel (AISI 300).
Use	For sheet hardnesses up to HRB 70.
Tools	
Insertion machines	

uniform resource locator: